

Our Quality • Your Assurance

CompDek 54

REVISED
EDITION



Comply with 2nd Generation EUROCODE 4



Celebrating Singapore's
Enterprising Spirit 2024
30 years



SWAN SWEE
CONSTRUCTION PTE LTD

ABOUT SWAN SWEE

SWAN SWEE
CONSTRUCTION PTE LTD

About Swan Swee Construction Pte Ltd

Since its establishment in 1992, Swan Swee Construction Pte Ltd has been a trusted name in the manufacture and supply of premium color-coated steel building products. Our comprehensive product portfolio includes painted steel roofing, wall cladding, galvanized high-tensile structural floor decking, galvanized high-tensile purlins, and a wide array of additional steel solutions such as crimp curved profiles, flashings, louvre panels, ventilators, and translucent sheeting. These high-performance products are engineered to meet the diverse needs of commercial, industrial, residential, and urban developments, ensuring reliability and durability across applications. At Swan Swee, we take pride in delivering a seamless supply chain experience. With extensive stock levels and a well-established distribution network, we align our operations with our customers' construction schedules, ensuring materials are delivered on-site precisely when needed. Our commitment to quality is underscored by a rigorous inspection and testing framework. We ensure every product complies with stringent regulatory requirements, technical standards, and codes of practice while exceeding customer expectations.

CompDek 54

CompDek 54 represents the latest advancement in re-entrant profile technology—a lineage that has underpinned Singapore's composite floor construction since 1980s. This next-generation profile is engineered for optimal structural performance, fire resistance, and service integration. The profile delivers a near-flat soffit, enhancing architectural appeal and simplifying ceiling finishes. It achieves industry-leading fire performance ratings for both slabs and supporting beams, making it ideal for compliance-driven projects.

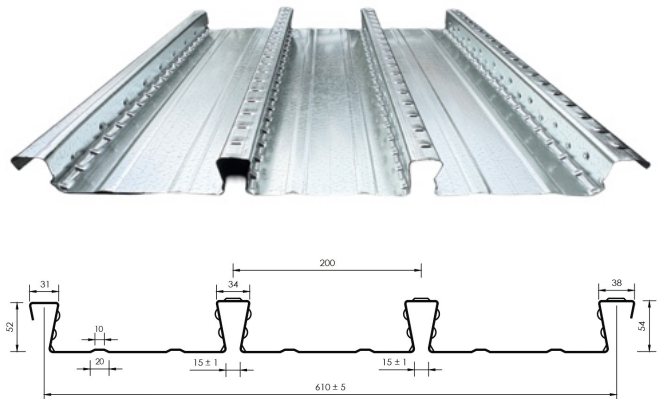

Precision-engineered embossments along the side of the pan, the top and the sides of the rib surfaces significantly improve mechanical interlock with concrete, resulting in superior longitudinal shear bond strength and enhanced composite slab capacity. The classic re-entrant geometry maximizes mechanical interlock between the steel deck and concrete, ensuring efficient shear transfer and minimizing slip at the steel-concrete interface. Dovetail-shaped longitudinal grooves at 200 mm centers provide robust anchorage points for M&E services, enabling flexible and secure suspension of utilities without compromising structural integrity.

Under the supervision of Prof. Stephen Hicks, CompDek 54 fire testing conducted at Warrington Fire Laboratory was carried out in accordance with the requirements of the second edition of Eurocode 4.

Prof. Hicks also served as advisor and technical manager for the formwork, composite action, and push-out performance tests undertaken in collaboration with the University of Warwick. The load tables published in this brochure are based on design values derived according to SS EN 1990 directly from the actual test data generated during the program at Warrington Fire Laboratory and the University of Warwick.

SPECIFICATION – CompDek 54

Thickness (BMT)	1.00mm	1.20mm	1.50mm
Grade of Steel (MPa)	G550	G500	G450
Coating (Galvanised) (min 275g/m ²)	Z275	Z275	Z275
Weight (Kg/m ²)	13.55	16.16	20.09

SPECIFICATION – CompDek 54

Per metre of width

Thickness (BMT) (mm)	Cross-section area	Profile weight	Second Moment of area	Section Modulus	Height to Centre of Gravity	Moment Capacity		Ultimate Shear Capacity
						Sagging	Hogging	
	A mm ²	kN/m ²	I _x 10 ⁴ mm ⁴	Z _x 10 ³ mm ³	Y _{cg} mm	kNm	kNm	kN
1.00	1,685	0.13	70.57	18.32	15.48	7.82	6.97	149.00
1.20	2,001	0.16	80.78	21.03	15.58	10.82	8.61	204.60
1.50	2,500	0.19	98.41	25.71	15.73	10.89	10.25	303.50

All civil and structural works are designed in compliance with the latest edition of the applicable standards and Code of Practice.

- **SSEN 1991-1: 2008** – Actions on Structure, Part 1
- **SSEN 1991-1-6: 2009** – Actions on Structure, Part 1-6
- **SSEN1993-1-3: 2010** – Design of steel structure, Part 1-3
- **SSEN 1993-1-5: 2009** – Design of steel structure, Part 1-5

CompDek 54 is in compliance with the second-generation Eurocode 4 (**EN 1994-1-1: 2026**)

Serviceability - FORMWORK

Vertical deflection

L_p/180 (but ≤ 20mm) When the effect of ponding is not considered.

L_p/130 (but ≤ 30mm) When the effect of ponding is considered.

where L_p is the effective span of the profiled steel sheets, which is the smaller of: distance between centres of permanent or temporary supports; and clear span between permanent or temporary supports plus overall depth of the profiled sheets

FORMWORK SPAN DESIGN

CompDek 54 plays a crucial role in the formwork stage of concrete construction, acting as both a temporary support structure and the permanent formwork for the concrete slab.

Structural Formwork Function

During the initial construction phase, CompDek 54 serves as a **stay-in-place formwork** for concrete slabs and may eliminate the need for temporary propping. It acts as a safe working platform and protects the workers below. It provides a stable base for pouring concrete without requiring additional temporary support structures like plywood or timber formwork. The decking supports the weight of wet concrete and construction loads until the concrete hardens.

Composite Action & Load Distribution

Once the concrete hardens, composite action develops such that CompDek 54 provides the main tension reinforcement to the slab. The decking's profiled shape improves load distribution, allowing for better performance under compressive and tensile forces. This results in thinner and lighter slabs without compromising strength, reducing material costs.

Material Benefits: Galvanised Steel

The galvanized coating — typically **zinc, Z275g/m²** — protects the steel from corrosion, ensuring long-term durability even in high-moisture environments. The galvanised coating prevents rust formation and extends the lifespan of the decking compared to non-coated steel. In fire conditions up to 500°C, the emissivity of the galvanized steel results in a smaller temperature increase to the composite slab.

Ribbed Profile for Improved Shear Connection with the Concrete

CompDek 54 is manufactured with a dovetail **rib and unique embossments** rolled into the ridge, the pan and at the side of the ribs which enhances mechanical interlock with the concrete. This augments the frictional interlock and minimizes the risk of separation between the slab and decking, leading to superior load-carrying capacity and crack resistance.

Speed & Efficiency in Construction

Using CompDek 54 simplifies construction logistics by eliminating traditional **temporary plywood formwork and props**. This speeds up installation and reduces labour-intensive formwork assembly and stripping. Since the decking is an integral part of the composite slab, there is no need for post-pour removal, minimizing waste and cleanup.

Design Loads for Formwork

CompDek 54 Formwork shall be designed to function as temporary formwork during two critical construction stages, in accordance with **SS EN 1991-1-6** and also in compliance with the second-generation **Eurocode 3 Part 1-3 (EN 1993-1-3: 2024)**.

Stage I – Pre-Concrete Placement

Prior to the placement of concrete, the formwork must accommodate the following load conditions:

- a. Handling and erection load encountered during installation.
- b. Pre-concrete placement loading, considering any imposed forces before pouring operations commence.

Stage II – Concrete Placement & Initial Curing

During the pouring and curing phase, CompDek 54 must support: Self-weight of the wet concrete until the material achieves structural integrity. Construction loads until the concrete reaches 75% of its design compressive strength, at which point it can begin to contribute flexural support for additional imposed loads.

Important note: No stacked material loads shall be applied until the concrete has adequately set and achieved the required early-stage flexural strength.

Recommended Deflection Limits for Formwork

According to the National Annex to **SS EN 1994-1-1**, a deflection limit of span/130, but less than 30 mm, is considered to be appropriate for profile steel sheeting in situations where visual quality is not significant.

COMPOSITE SLAB

The efficiency of the composite slab is governed by the interaction between the steel sheeting and the concrete slab. Studies have demonstrated that shear strength [SH3.1] at the interface between the steel sheeting and surrounding concrete is the primary factor influencing the structural behaviour of the composite slab. *In reference to the book coauthored by [Johnson, Roger Paul and Hicks, Stephen J. (2025) Designers' Guide to EN 1994-1-1: 2026 : Eurocode 4 : design of composite steel and concrete structures : part 1.1 general rules and rules for buildings. Leeds: ICE Publishing. ISBN 9781836629214].*

Whilst chemical bond between the steel sheeting and concrete contributes to composite action, it is not considered effective for design according to **SS EN 1994-1-1**. Once the chemical bond is lost, the dependable mechanical and frictional interlock between the steel sheeting and concrete take over to resist slip. The effectiveness of these mechanisms depends on several parameters, including rib geometry, sheet thickness, and the size and frequency of embossments. Design methodologies for composite slabs are based on, the latest edition of the following relevant standards and Code of Practice.

SS EN 1991-1-1: 2008 – Actions on Structures: Part 1-1

SSEN 1993-1-3: 2010 – Design of Steel Structures: Part 1-3

SS EN 1991-1-6: 2009 – Actions on Structures: Part 1-6

SS EN 1993-1-5: 2009 – Design of Steel Structures: Part 1-5

Role of Embossments in Steel Floor Decking Systems

Embossments-engineered indentations or lugs formed into the profile of steel floor decking-serve as critical mechanical interlocks that facilitate composite action between the steel deck and cast-in-place concrete. These features function as integral shear connectors, enabling the two materials to behave as a unified structural system and effectively resist longitudinal shear forces at their interface.

Primary Functions of Embossments:

● 1. Enable Composite Action

Embossments allow the steel deck and concrete slab to act monolithically as a composite floor system, significantly enhancing flexural capacity and stiffness compared to non-composite assemblies.

● 2. Prevent Interface Slippage

The mechanical keying effect of embossments ensures a secure bond between the cured concrete and steel substrate, mitigating relative movement under service loads and maintaining structural integrity.

● 3. Resist Horizontal Shear Forces

By anchoring the concrete to the steel deck, embossments counteract shear-bond stresses that develop due to differential strain, particularly under bending and dynamic loading conditions.

● 4. Enhance Load Transfer and Floor Strength

The interfacial bond created by embossments facilitates efficient load transfer between materials, increasing the overall load-bearing capacity, stiffness, and durability of the floor system.

Embossment on Steel Floor Decking

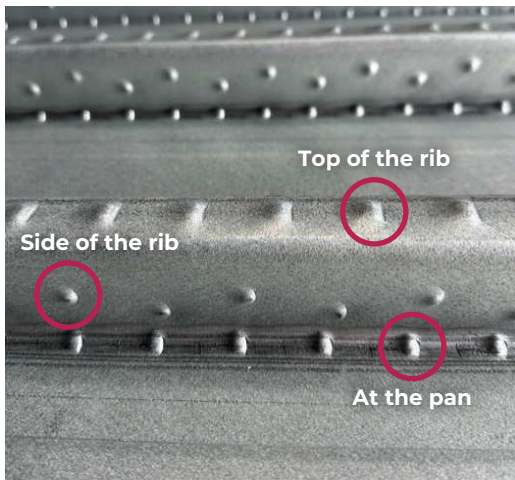

Eurocode 4 requires that composite slabs provide sufficient longitudinal shear transfer between the steel sheeting and concrete. This is typically achieved through mechanical interlock (e.g. embossments), friction, and/or end anchorage, since bond alone is not considered adequate.

The effectiveness of a given decking profile (including embossment arrangement) is not prescribed by the code but must be demonstrated through testing to establish its longitudinal shear resistance.

If the shear connection is insufficient, slip can occur at the interface, leading to partial composite action and reduced bending resistance.

CompDek54 with an additional embossment (a third embossment) can improve mechanical interlock and may increase the tested shear capacity, potentially enabling more efficient designs.

In determining the maximum imposed load on the composite slab, the following design consideration are outlined as follows:

Concrete Grade

The concrete grade to evaluate the maximum imposed load of the composite slab is 25MPa, 30 MPa and 40MPa.

Slab Span and Thickness

The slab span and slab thickness to evaluate the maximum imposed load of the composite slab ranges from 1.8 m to 7.0 m (0.2 m intervals) and ranging from 90 mm to 250mm (10mm interval), respectively.

Reinforcement

Minimum reinforcement is assumed to evaluate the maximum imposed load of the composite slab. According to **SS EN 1994-1-1**, where continuous slabs are designed as simply-supported, the cross-sectional area of reinforcement above the ribs should not be less than 0.2% and 0.4% of the cross-sectional area of the concrete above the ribs for unpropped and propped construction, respectively.

End Bearing

According to **SS EN 1994-1-1**, the minimum end bearing for the composite slab supported on steel or concrete is 50 mm. The CompDek shall be fixed to ensure connection between the sheet 8 and supporting beams and to keep in position.

LOAD SPAN TABLE

1.00mm

1.00 mm CompDek 54 (G550)

Load span tables for normal weight concrete – single span

Slab Depth (mm)	Concrete Volume (m ³ /m ²)	Total Applied Load (kN/m ²) SLS					
		5.5	7.0	8.5	10.0	11.5	13.0
110	0.103	2.82	2.82	2.82	2.82	2.82	2.82
120	0.113	2.74	2.74	2.74	2.74	2.74	2.74
130	0.123	2.67	2.67	2.67	2.67	2.67	2.67
140	0.133	2.60	2.60	2.60	2.60	2.60	2.60
150	0.143	2.54	2.54	2.54	2.54	2.54	2.54
160	0.153	2.49	2.49	2.49	2.49	2.49	2.49
170	0.163	2.44	2.44	2.44	2.44	2.44	2.44
180	0.173	2.39	2.39	2.39	2.39	2.39	2.39
190	0.183	2.35	2.35	2.35	2.35	2.35	2.35
200	0.193	2.31	2.31	2.31	2.31	2.31	2.31

1.00 mm CompDek 54 (G550)

Load span tables for normal weight concrete – double span

Slab Depth (mm)	Concrete Volume (m ³ /m ²)	Total Applied Load (kN/m ²) SLS					
		5.5	7.0	8.5	10.0	11.5	13.0
110	0.103	3.36	3.36	3.36	3.36	3.36	3.36
120	0.113	3.28	3.28	3.28	3.28	3.28	3.28
130	0.123	3.20	3.20	3.20	3.20	3.20	3.20
140	0.133	3.14	3.14	3.14	3.14	3.14	3.14
150	0.143	3.06	3.06	3.06	3.06	3.06	3.06
160	0.153	3.01	3.01	3.01	3.01	3.01	3.01
170	0.163	2.95	2.95	2.95	2.95	2.95	2.95
180	0.173	2.89	2.89	2.89	2.89	2.89	2.89
190	0.183	2.84	2.84	2.84	2.84	2.84	2.84
200	0.193	2.79	2.79	2.79	2.79	2.79	2.79

1.00 mm CompDek 54 (G550)

Load span tables for normal weight concrete – One line of 100mm wide props at mid-span

Slab Depth (mm)	Concrete Volume (m ³ /m ²)	Total Applied Load (kN/m ²) SLS					
		5.5	7.0	8.5	10.0	11.5	13.0
110	0.103	4.69	4.33	4.06	3.84	3.67	3.52
120	0.113	4.88	4.69	4.43	4.20	4.01	3.83
130	0.123	4.93	4.76	4.57	4.38	4.17	3.96
140	0.133	4.97	4.82	4.65	4.47	4.28	4.08
150	0.143	5.01	4.87	4.71	4.55	4.37	4.19
160	0.153	5.04	4.91	4.77	4.62	4.46	4.29
170	0.163	5.07	4.95	4.82	4.68	4.53	4.37
180	0.173	5.05	4.98	4.86	4.73	4.59	4.45
190	0.183	4.95	4.95	4.90	4.78	4.65	4.51
200	0.193	4.87	4.87	4.87	4.82	4.70	4.57

1.20mm

1.20 mm CompDek 54 (G500)

Load span tables for normal weight concrete – single span

Slab Depth (mm)	Concrete Volume (m ³ /m ²)	Total Applied Load (kN/m ²) SLS					
		5.5	7.0	8.5	10.0	11.5	13.0
110	0.103	2.94	2.94	2.94	2.94	2.94	2.94
120	0.113	2.86	2.86	2.86	2.86	2.86	2.86
130	0.123	2.78	2.78	2.78	2.78	2.78	2.78
140	0.133	2.71	2.71	2.71	2.71	2.71	2.71
150	0.143	2.65	2.65	2.65	2.65	2.65	2.65
160	0.153	2.59	2.59	2.59	2.59	2.59	2.59
170	0.163	2.54	2.54	2.54	2.54	2.54	2.54
180	0.173	2.49	2.49	2.49	2.49	2.49	2.49
190	0.183	2.45	2.45	2.45	2.45	2.45	2.45
200	0.193	2.41	2.41	2.41	2.41	2.41	2.41

1.20 mm CompDek 54 (G500)

Load span tables for normal weight concrete – double span

Slab Depth (mm)	Concrete Volume (m ³ /m ²)	Total Applied Load (kN/m ²) SLS					
		5.5	7.0	8.5	10.0	11.5	13.0
110	0.103	3.80	3.80	3.80	3.80	3.74	3.59
120	0.113	3.72	3.72	3.72	3.72	3.72	3.72
130	0.123	3.64	3.64	3.64	3.64	3.64	3.64
140	0.133	3.56	3.56	3.56	3.56	3.56	3.56
150	0.143	3.48	3.48	3.48	3.48	3.48	3.48
160	0.153	3.41	3.41	3.41	3.41	3.41	3.41
170	0.163	3.34	3.34	3.34	3.34	3.34	3.34
180	0.173	3.28	3.28	3.28	3.28	3.28	3.28
190	0.183	3.22	3.22	3.22	3.22	3.22	3.22
200	0.193	3.16	3.16	3.16	3.16	3.16	3.16

1.20 mm CompDek 54 (G500)

Load span tables for normal weight concrete – One line of 100mm wide props at mid-span

Slab Depth (mm)	Concrete Volume (m ³ /m ²)	Total Applied Load (kN/m ²) SLS					
		5.5	7.0	8.5	10.0	11.5	13.0
110	0.103	4.78	4.41	4.13	3.92	3.74	3.59
120	0.113	5.01	4.81	4.51	4.28	4.08	3.91
130	0.123	5.07	4.89	4.70	4.49	4.28	4.06
140	0.133	5.12	4.95	4.78	4.59	4.39	4.18
150	0.143	5.16	5.01	4.84	4.67	4.49	4.29
160	0.153	5.19	5.05	4.90	4.74	4.57	4.39
170	0.163	5.22	5.09	4.95	4.80	4.65	4.48
180	0.173	5.24	5.12	5.00	4.86	4.71	4.56
190	0.183	5.26	5.15	5.04	4.91	4.77	4.63
200	0.193	5.28	5.18	5.07	4.95	4.82	4.69

1.50mm

1.50 mm CompDek 54 (G450)

Load span tables for normal weight concrete – single span

Slab Depth (mm)	Concrete Volume (m ³ /m ²)	Total Applied Load (kN/m ²) SLS					
		5.5	7.0	8.5	10.0	11.5	13.0
110	0.103	3.13	3.13	3.13	3.13	3.13	3.13
120	0.113	3.04	3.04	3.04	3.04	3.04	3.04
130	0.123	2.96	2.96	2.96	2.96	2.96	2.96
140	0.133	2.89	2.89	2.89	2.89	2.89	2.89
150	0.143	2.82	2.82	2.82	2.82	2.82	2.82
160	0.153	2.76	2.76	2.76	2.76	2.76	2.76
170	0.163	2.71	2.71	2.71	2.71	2.71	2.71
180	0.173	2.66	2.66	2.66	2.66	2.66	2.66
190	0.183	2.61	2.61	2.61	2.61	2.61	2.61
200	0.193	2.57	2.57	2.57	2.57	2.57	2.57

1.50 mm CompDek 54 (G450)

Load span tables for normal weight concrete – double span

Slab Depth (mm)	Concrete Volume (m ³ /m ²)	Total Applied Load (kN/m ²) SLS					
		5.5	7.0	8.5	10.0	11.5	13.0
110	0.103	3.86	3.86	3.86	3.86	3.83	3.68
120	0.113	3.78	3.78	3.78	3.78	3.78	3.78
130	0.123	3.70	3.70	3.70	3.70	3.70	3.70
140	0.133	3.62	3.62	3.62	3.62	3.62	3.62
150	0.143	3.55	3.55	3.55	3.55	3.55	3.55
160	0.153	3.48	3.48	3.48	3.48	3.48	3.48
170	0.163	3.42	3.42	3.42	3.42	3.42	3.42
180	0.173	3.36	3.36	3.36	3.36	3.36	3.36
190	0.183	3.30	3.30	3.30	3.30	3.30	3.30
200	0.193	3.24	3.24	3.24	3.24	3.24	3.24

1.50 mm CompDek 54 (G450)

Load span tables for normal weight concrete – One line of 100mm wide props at mid-span

Slab Depth (mm)	Concrete Volume (m ³ /m ²)	Total Applied Load (kN/m ²) SLS					
		5.5	7.0	8.5	10.0	11.5	13.0
110	0.103	4.90	4.52	4.24	4.01	3.83	3.68
120	0.113	5.23	4.94	4.63	4.38	4.18	4.02
130	0.123	5.31	5.13	4.92	4.71	4.48	4.26
140	0.133	5.36	5.19	5.01	4.81	4.60	4.39
150	0.143	5.40	5.24	5.07	4.89	4.70	4.50
160	0.153	5.43	5.29	5.13	4.96	4.78	4.60
170	0.163	5.46	5.33	5.18	5.03	4.86	4.69
180	0.173	5.48	5.36	5.23	5.08	4.93	4.76
190	0.183	5.51	5.39	5.26	5.13	4.99	4.83
200	0.193	5.53	5.42	5.30	5.17	5.04	4.89

The load span tables have been developed based on the following assumptions:

The span indicates the maximum permissible centre-to-centre distance (in mm) between supports. The provided spans are effective spans, which is advised to be the lesser of:

- The distance between centres of permanent or temporary supports.
- The clear span between or temporary supports plus the overall depth of the profiled sheets.

A minimum support width of 152 mm for internal supports, 50 mm for end supports and a 100 mm prop width.

An imposed construction load of $Q_{cc} = 0.5 \text{ kN / m}^2$ and $Q_{ca} = 0.75 \text{ kN / m}^2$ is taken in accordance with the NA to **SS EN 1991-1-6**.

The total applied loads in the tables correspond to an allowable unfactored total load. The total load combination is made up of:

- An imposed live load
- Ceiling and services
- Finishes
- Partition loads

However, the dead load of the slab itself has already been taken into account and need not be considered as part of the applied load.

Concrete grade C25/30, with a characteristic compressive strength of 25 Mpa.

Construction stage deflection: span/130 but less than 30mm where the loads from ponding are included in accordance with the NA to **SS EN 1994-1-1**.

Resistance of composite slab moment resistance calculated via the partial connection method.

Composite stage deflection criteria:

Under imposed load: limited to $\text{span}/350$ or 20 mm (whichever is less)

Under total load: limited to $\text{span}/250$ or 30 mm (whichever is less)

The spans are based on the following design checks:

Single Span

- Construction bending resistance
- Construction deflection
- Construction crushing resistance at the supports
- Composite bending resistance
- Composite deflection
- Composite vertical shear resistance
- Composite natural frequency

Double Span

- Construction
 - ULS Check: One span loaded according to **EN 1991-1-6**
 - SLS Check: Both spans loaded according to **EN 1991-1-6**
 - ULS Check: Both spans loaded according to **EN 1991-1-6**
- Composite bending resistance
- Composite deflection
- Composite vertical shear resistance
- Composite natural frequency

Double Span with Single Line of Props at Mid Span

- Construction combined bending and crushing over the props (no redistribution) and crushing over the props (no redistribution of hogging moment permitted).
- Composite bending resistance
- Composite deflection
- Composite vertical shear resistance
- Composite natural frequency

LOAD TESTING – University of Warwick IN ACCORDANCE TO EN 1993-1-3: 2024 AND EN 1994-1-1: 2026

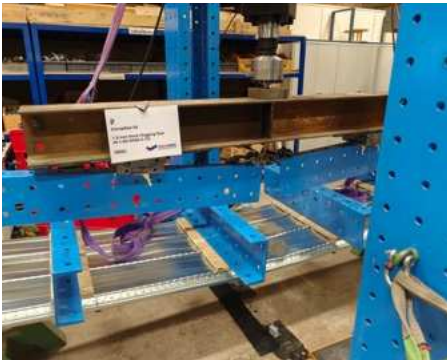

1.00mm Hogging & Sagging

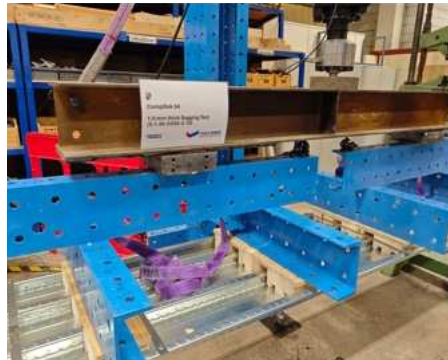

1.20mm Hogging & Sagging



1.50mm Hogging & Sagging



LOAD TESTING – University of Warwick

IN ACCORDANCE TO EN 1993-1-3: 2024 AND EN 1994-1-1: 2026

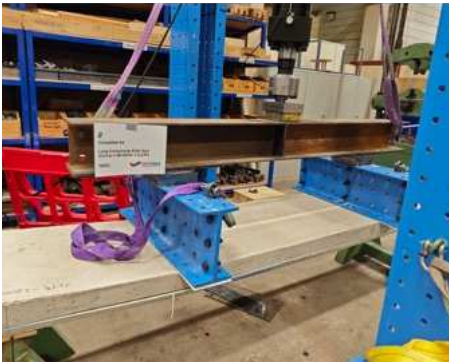

1.00mm – Long & Short Composite Slab (LTF)

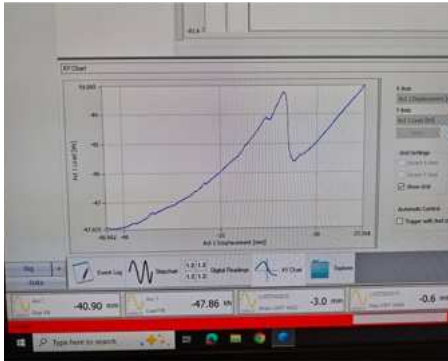

1.00mm – Long Composite Slab test (load to failure following the more onerous 5000 load cycles)



1.00mm – Push Out Test

LOAD TESTING – University of Warwick

IN ACCORDANCE TO EN 1993-1-3: 2024 AND EN 1994-1-1: 2026

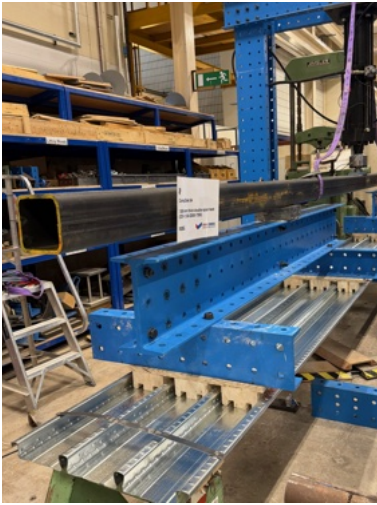

1.00mm Double Span Test

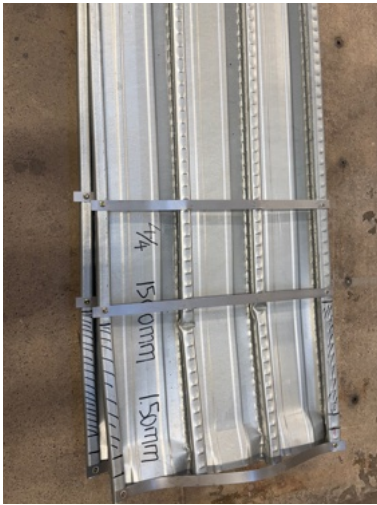
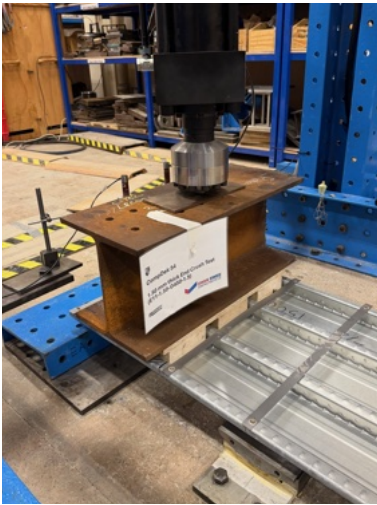

1.50mm End Crush Test

Slab Thickness and Reinforcement

Normal conditions:

- The overall depth of the composite slab h shall be not less than 80 mm. The thickness of concrete h_c above the main flat surface of the top of the ribs of the sheeting shall be not less than 40mm.
- If the slab is acting compositely with the beam or is used as a diaphragm, the total depth shall be not less than 90mm and h_c shall be not less than 50 mm.
- The overall minimum depth of the composite slab, denoted as h , shall be established based on the criteria outlined in the accompanying illustration, in accordance with **SS EN 1994-1-1, Clause 9.2.1**.

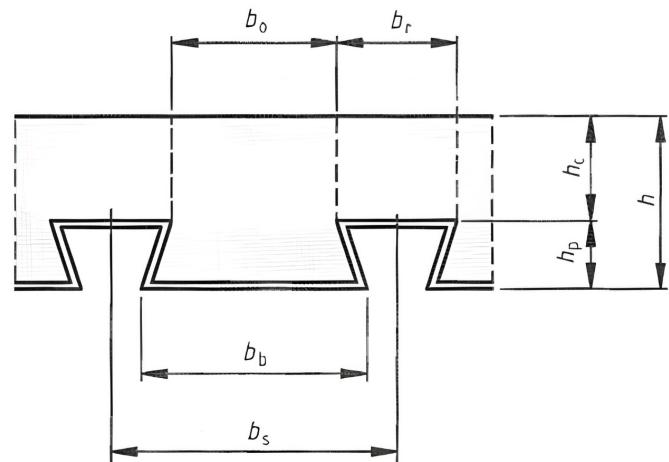

Fire conditions:

- The overall depth of the composite slab (h) shall not be less than the values given in Table x.

Minimum Thickness of Concrete (mm) for a Fire Resistance (FR) Period (mins)				
FR Period (mins)	Insulation-30	Insulation-60	Insulation-90	Insulation-120
Thickness (mm)	100	100	110	125

Table x: Minimum insulation thickness for composite slabs using CompDek 54.

Composite Steel Beam Design

Composite slabs and beams are widely used in commercial and industrial buildings due to their efficiency in construction speed and cost-effectiveness. Savings in steel weight of between 30 to 50% can be achieved compared to non-composite beams. Also, the increased stiffness of composite beams can result in them being shallower than non-composite beams for the same span, which can lead to lower storey heights and a reduction to cladding costs, or allowing more room for mechanical services.

Typically, composite beams consist of hot-rolled or fabricated steel sections that work in conjunction with the concrete slab acting as the compression flange. Composite action is developed between the steel section and the concrete slab by shear connectors affixed to the top of the beam, commonly in the form of headed studs. These studs can be welded either in the workshop or on-site through the decking.

For optimal design efficiency and continuity of decking sheets, it is recommended that shear studs be welded off-site [SH4.1] within the controlled environment of a steel fabricator yard. This approach enhances structural integrity and allows for more economical designs. The shear connectors play a crucial role in ensuring adequate longitudinal shear transfer between the beam and the concrete, enabling them to act as a unified composite system.

Eurocode 4 (EN 1994-1-1) – Design of composite steel and concrete structures - General rules and rules for buildings.

Eurocode 2 (EN 1992-1-1) – Concrete properties and related checks, including longitudinal shear.

Eurocode 3 (EN 1993-1-1) – Design of steel structures, including construction stage considerations.

BC4:2021 – Singapore's Building and Construction Authority (BCA) guide for steel-concrete composite columns.

Shear Connector Location Details

The CompDek 54 profile features a flat pan centre, enabling shear studs to be positioned centrally within the pan in all cases according to **SS EN 1994-1-1**. This design simplifies both installation and structural detailing, ensuring consistent placement and optimal composite action.

Minimum Height of Shear Connectors, h_{sc}

According to **EN 1994-1-1, Clause 6.6.5.8(1)**, the height of a shear stud (h_{sc}) must extend at least $2d$ above the top of the steel deck, where d represents the diameter of the stud shank. This requirement ensures adequate embedment and effective composite action between the steel beam and concrete slab.

BC4:2021 – Singapore's Building and Construction Authority (BCA) guide for steel-concrete composite structures.

AWS D1.1/D1.5 – Welding codes that govern shear stud welding procedures.

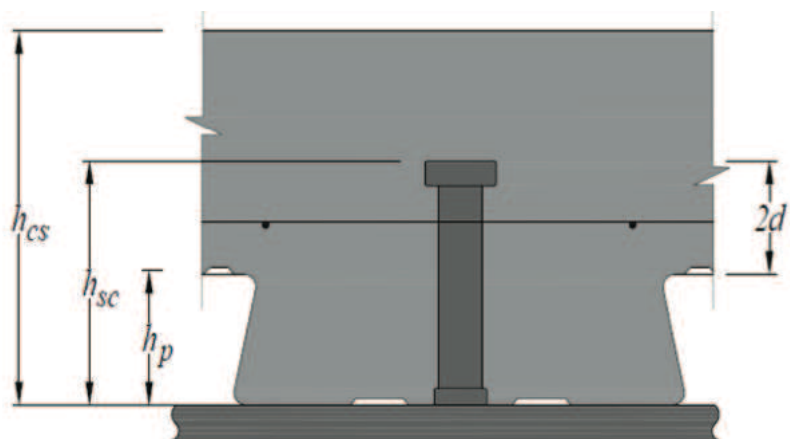

The table below presents the minimum height requirements for shear connectors used in CompDek 54® within composite slab and composite beam designs. These values ensure proper embedment and effective composite action between the steel beam and concrete slab.

Recommend Shear Standard height, h_{sc}

Deck Profile	Rib Height, h _p (mm)	Diameter, d (mm)	Min as-welded Stud Height, h _{sc} = h _p + 2d (mm)	Recommended as-welded Stud Height, h _{sc}
CompDek	54	19	54 + (2 × 19) = 92	100mm

Fire Considerations in Composite Slab Design

- **Structural Safety:** Fire tests show how long slabs can carry design loads without collapse, even when steel components lose strength.
- **Fire Integrity & Insulation:** Floors must act as barriers, preventing the passage of flames and hot gases from spreading upward, whilst restricting the temperature rise of the unexposed face to below limits specified in **EN 1363-1**.
- **Mechanical Behaviour:** Loaded fire testing ensures that composite floor slabs perform reliably under elevated temperatures, and demonstrate adequate rotation capacity.
- **Design Validation:** Fire test data calibrates engineering models, leading to optimized reinforcement and a reduction in fire protection costs.
- **Nominal fire exposure:** Eurocode 4 defines the failure criteria for nominal fire exposure, as follows: load bearing capacity (R); integrity (E); and insulation (I). A structural element must maintain adequate load bearing capacity for the required period in fire conditions and, if it is also a separating element, then insulation and integrity criteria must also be fulfilled. Composite floor slabs are often designed to be separating elements and must therefore behave adequately in accordance with each of these performance criteria.
- **Basis for design:** According to Eurocode 4, the design resistance in the fire situation may be evaluated from: tabulated design data; simplified design methods; or advance design methods. Alternatively, fire design may be based on the results of fire tests, or on fire tests in combination with calculations. The appropriate standard for fire tests on composite floors slabs is **EN 1365-2**.
- **Code Compliance:** Certified fire resistance ratings (e.g., 60, 90, 120, 240 minutes) are required to meet building regulations.
- **Post-Fire Performance:** Tests also assess whether slabs remain repairable and structurally sound after exposure to fire.

Fire testing in steel floor decking for composite slabs verifies structural integrity under heat, ensuring the system meets safety regulations while maximizing load-bearing capacity.

Tests confirm how concrete and steel work together (composite action) to resist bending, prevent premature collapse, and validate fire resistance ratings (typically 30, 60, 90–120+ minutes)

Key Reasons for Fire Testing in Composite Slab Design:

- **Verification of Structural Behavior:** Tests confirm that despite the steel deck losing strength at high temperatures, the composite assembly (concrete + steel) maintains integrity through Tensile Membrane Action (TMA), where the slab supports load even if the steel deck buckles.
- **Safety Regulations Compliance:** Fire tests (like **EN 1363-1**) are necessary to gain approval from regulatory authorities for fire-rated assemblies.
- **Optimization of Design:** Testing allows engineers to refine reinforcement layouts, slab thickness, and deck profiles for more economical and efficient designs.
- **Insulation and Integrity Performance:** The tests measure how well the concrete thickness protects the steel and provides insulation to prevent fire spread to upper floors.
- **Material Interaction:** Tests determine how much the steel decking separates from the concrete, which impacts heat transfer and overall structural strength during a fire.

Fire testing ensures that these systems are both safe and efficient, allowing for reduced fireproofing materials while ensuring the structure withstands potential fire events.

Fire Testing Result:



Profile: CompDek 54

Test Results:

Loadbearing Capacity		254 minutes
Integrity Performance	Sustained Flaming	254 minutes
	Gap Gauge	254 minutes
	Cotton Pad	254 minutes
Insulation Performance		203 minutes

Test Sample: 1.00mm BMT G550 MPa
Clear Span: 3600mm
Slab Thickness: 130mm
Uniformly distributed load of 5.5 kN/m²

FIRE TESTING

FIRE TESTING – Warringtonfire Laboratory IN ACCORDANCE TO EN 1365-2: 2014



Setting Up Furnace and Loading Frames



Testing of 1.00mm CompDek 54



Apply 5.5 Kpa on the Test Specimen



Slab Ready for the Fire Test



View From Inside the Furnace



Recording of Fire Test Exceeding 4 Hours Duration

FIRE TESTING – Warringtonfire Laboratory **IN ACCORDANCE TO EN 1365-2: 2014**

The exposed face of the floor assembly prior to testing

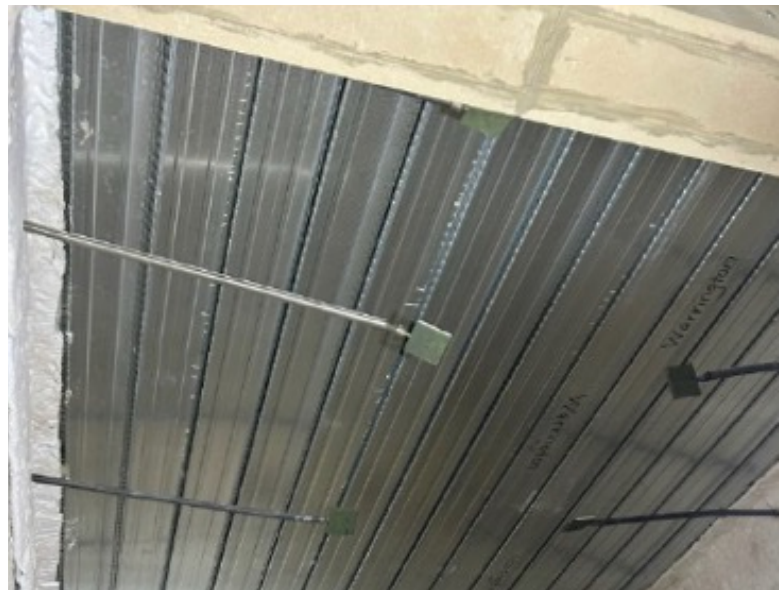

The exposed face of the floor assembly immediately after the test

Openings in Slabs

Openings can be readily incorporated into composite slabs by boxing out before pouring the concrete and cutting the deck once the concrete has fully cured.

Small Openings ($\leq 300\text{mm}$):

Openings up to 300mm square generally do not require additional reinforcement.

Medium to Large Openings ($>300\text{mm}$):

Openings greater than 300mm must be designed by a qualified engineer, with additional reinforcement placed around the perimeter. **Openings up to 700mm** can be accommodated using the same boxing-out method before pouring concrete, followed by cutting the deck after curing.

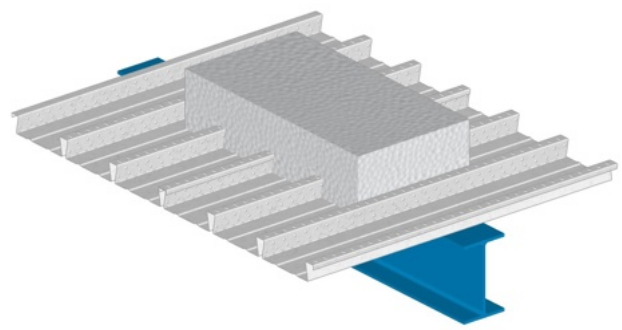
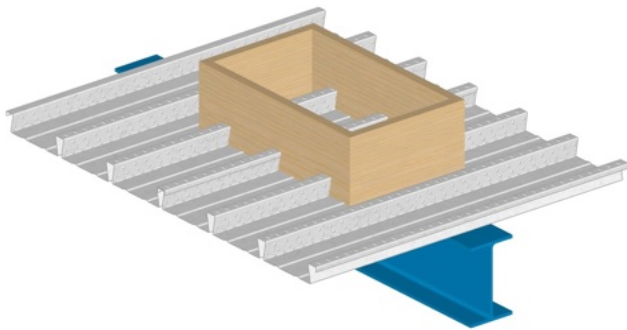

Important Note:

The steel deck must not be cut before concreting or before the concrete has fully cured, as this could compromise structural integrity.

Cutting and Installing Edgeform

Edgeform is a streamlined C-shaped section designed to simplify the installation of most CompDek 54 slabs. It securely fastens to the CompDek 54 sheeting, effectively retaining the concrete while providing a smooth top edge for precise and efficient screeding. Engineered to accommodate any slab thickness, Edgeform enhances both accuracy and ease of installation. This section can be easily spliced and bent to form internal and external corners at any angle. It must be properly positioned and fully secured as the sheets are installed.

For unsupported CompDek 54 panels, Edgeform should be fastened to the underside at 300mm intervals. Additionally, its top flange must be tied to the ribs every 600mm to ensure stability. Typically, Edgeform is made from galvanized steel, 1mm thick ($Z275 \text{ g/m}^2$), offering corrosion protection equivalent to the steel deck.

External corner

1. Notch top flange for the required angle

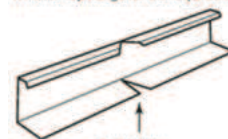

2. Cut 'V' in bottom flange

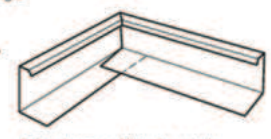

3. Bend corner of Edgeform to the required angle, overlapping bottom flanges.

Internal corner

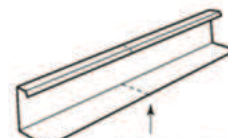

1. Cut top and bottom flanges square.

Fastening top flange of Edgeform

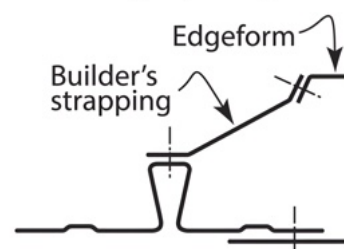

Deck Fixing

Once the deck is laid, it must be secured through its trough to the tops of the supporting structure without delay. Fixing is typically done using powder-actuated pins or self-drilling screws. Additionally, side lap fixings should be installed at 100mm intervals to ensure stability.

Fixing Spacing:

End Fixing: 2 fixings per sheet

Immediate Supports: 1 fixing per sheet

Side Fixing onto Support: 1 fixing at 600mm intervals

Laying of CompDek 54

CompDek 54 sheets must be installed with their sheeting ribs aligned in the direction of the designed spans to ensure structural integrity.

Installation Guidelines:

Slab supports must be properly prepared to accommodate bearing and slip joints as required. Lay CompDek 54 sheets continuously across each slab span without intermediate splicing or jointing to maintain structural performance. Position sheets end to end, ensuring that joints are centralized at slab supports. If jointing material is necessary, sheets may be butted against the joining material.

To support wet concrete and construction loads, the minimum bearing must be:

- **50 mm** at the ends of CompDek 54 sheets
- **100 mm** at intermediate supports where the sheeting is continuous

End Bearing and sheared bearing
(Minimum 50mm)

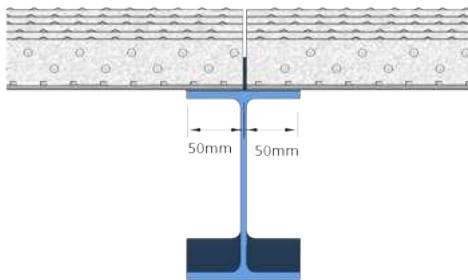

Continuous bearing
(Minimum 100mm)

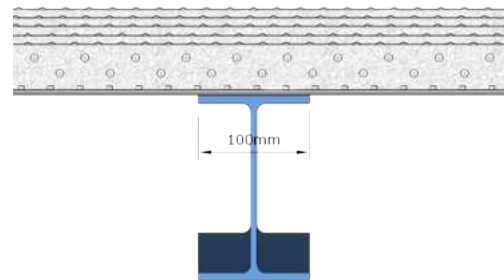

For exposed applications, the end, and edges of CompDek 54 sheets must be treated with a suitable edge protection to prevent moisture ingress.

Casting Concrete

Before pouring concrete, ensure that the decking is free from dirt and grease, as contaminants can negatively impact the hardened slab's performance. However, residual oil from the roll-forming process does not require removal.

Concrete should be poured uniformly, following a consistent directional (in the direction of span) sequence to maintain structural integrity. Care must be taken to prevent excessive accumulation of concrete in any area during the casting process. Construction and day joints should be positioned over a support beam, ideally aligning with deck joints for optimal load distribution.

Temporary Propping

The main contractor is responsible for the safe design and installation of temporary props. When the structural design necessitates temporary supports, they must ensure continuous reinforcement of the profile sheeting. Spreader beams (timber members) should be employed, supported by temporary props spaced at one-metre intervals. If the design span exceeds the decking's load-bearing capacity during construction, additional temporary supports must be used to sustain the weight of the concrete and imposed construction loads.

Props must be inherently stable and should not rely on friction with the deck for structural integrity. The end props in each row must be self-supporting and securely braced to the internal props. Temporary propping should only be removed once the concrete has attained sufficient compressive strength to safely bear the intended superimposed loads.

Preventing Slurry Leakage

To maintain a clean underside on the decking during the concrete pour, it is crucial to prevent slurry leakage, which can cause unsightly stains. To minimize leakage under the sheets, apply foam tape beneath the deck edges where they meet the supporting structure. This ensures a tight seal, preventing concrete from seeping through gaps and preserving the integrity of the deck's appearance.

Care and Storage Before Installation

CompDek 54 is delivered in strapped bundles. If not required for immediate use, stack sheets or bundles neatly and elevated from the ground on a slight slope to facilitate water drainage. If stored outdoors, ensure they are covered with waterproof protection. Prevent rainwater or condensation from becoming trapped between sheets, as this may lead to material degradation. To minimize the risk of damage, open bundles only when installation is about to commence. Verify that all necessary temporary supports are in place before proceeding with the decking installation.

When lifting bundles, the use of appropriate lifting equipment is recommended. Unprotected chain slings may damage the bundle during hoisting. When using synthetic slings, be cautious of potential severing at the edges of the decking sheets. If timber packers are utilized, they must be securely fastened to the bundle before lifting to the ground. Bundles must never be lifted using the metal banding, as this may compromise safety and structural integrity.

Skill Cutting of CompDek 54

At Swan Swee, safety and productivity are more than priorities - they are the very foundation of every project we undertake. Among steel fabricators, working at height remains one of the most significant risks, and we are dedicated to eliminating these hazards while enhancing efficiency. Conventional steel cutting at height not only poses serious safety challenges but also generates disruptive noise and slows the installation of floor decking.

To overcome these limitations, Swan Swee has invested in a cutting-edge robotic laser cutter engineered specifically for galvanised steel decking. By relocating cutting operations to a controlled factory environment, we deliver precision, consistency, and uncompromising quality.

The outcome: pre-cut decking panels arrive on site ready for seamless integration into steel frame structures. This innovation reduces on-site risks, accelerates installation, strengthens quality control, and eliminates cutting noise - enabling our customers to achieve safer, faster, and more reliable results.

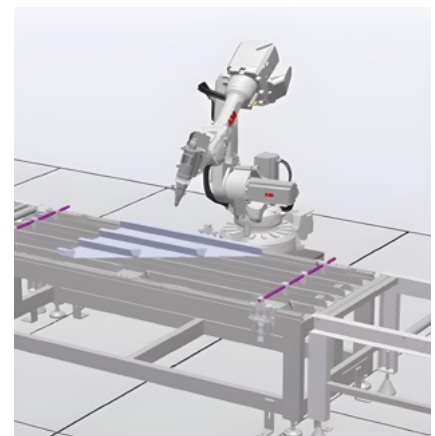
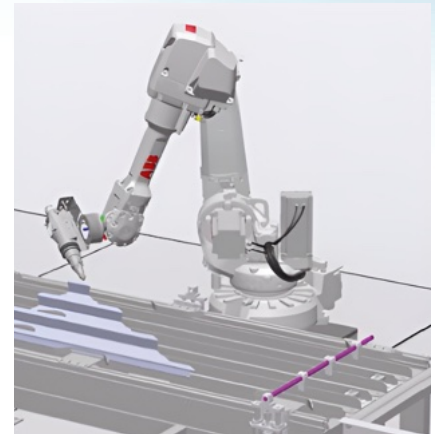

Robotic Cutter

Angle of Cut:

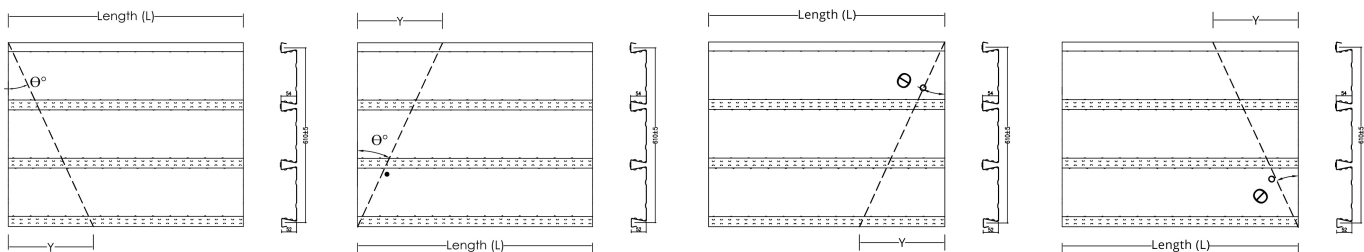

Length and Transportation Guidelines

Custom Lengths: **CompDek 54** is supplied pre-cut to the required dimensions.

Standard Length Limitation: For standard deliveries, the material length should not exceed **12 metres**.

Special Transportation for Extended Lengths: Lengths greater than 12 metres necessitate specialized transportation and appropriate on-site handling facilities.

Regulatory Compliance: Always conform to the **transportation limits set by LTA** (Land Transport Authority) to ensure adherence to regulations for long products. Proper planning ensures safe, efficient delivery and handling of the materials.

THE SECOND GENERATION OF EUROCODE 4 (1/2)

The second-generation of Eurocode 4 (**EN 1994-1-1: 2026**) introduces significant implications for the current market in steel floor decking systems. Decking systems previously assessed under the traditional m–k method must either undergo re-testing to demonstrate conformity with the revised provisions, or alternatively, incorporate supplementary reinforcement bars to satisfy the updated performance criteria.

For systems relying on historic m–k test data, compliance requires either:

- Re-evaluation of legacy test results, provided that the slab–deck interaction can be classified as ductile in accordance with **EN 1994-1-1: 2026, Clause 10.7.2(3)**, and that the test specimens comply with the standard test requirements in **EN 1994-1-1: 2026, Annex B.4**.
- New product testing according to **EN 1994-1-1: 2026, Annex B.4** to quantify shear bond resistance using the partial connection method.

Additionally, according to **Clause 10.7.2(11) of EN 1994-1-1: 2026**, a reduction to the bending resistance of composite slabs that include supplementary reinforcement bars for fire design considerations (or decks that rely on the historic m-k method) may be required when the plastic neutral axis is deep within the cross-section. This requirement is intended to prevent premature crushing of the concrete slab before the reinforcing bars and steel deck can achieve their yield strength, thereby ensuring structural reliability and compliance with the enhanced safety margins mandated by the revised code.

Standard tests for shear connectors and composite floor slabs are now provided within the Normative Annex B, which has the same status as the main body of **EN 1994-1-1: 2026** (Annex B was informative in the first generation Eurocode 4). As a consequence of this, floor systems that were based on tests with an additional line load in the shear span, or small scale tests that were not subject to bending, are no longer supported by the second generation of Eurocode 4 and additional testing may be required. In addition, there is a change in the scope for tests on composite slabs, where experimental results cannot be applied to a deck with a higher yield strength than that tested.

THE SECOND GENERATION OF EUROCODE 4 (2/2)

Vertical shear in composite slabs is not normally critical, unless there are line loads (walls) or concentrated point loads (including plant, machinery or props) applied to the floor. In the past, composite slabs have traditionally been assessed as for reinforced concrete slabs according to Eurocode 2. **EN 1994-1-1: 2026, Clause 10.7.5(2) and 10.7.5(7)** introduces two design models that recognise the beneficial contribution of the decking, thereby providing comparable resistances as reinforced concrete slabs but with significantly less reinforcement bars.

In the design of composite beams, the presence of steel decking ribs transverse to the steel beam reduces the resistance of the stud connectors. For long-span composite beams, the deck ribs have sometimes restricted designs because it has been difficult to satisfy the minimum degree of shear connection requirements as there is only a finite number of available positions along the beam to weld the studs. To remedy this situation, **EN 1994-1-1: 2026, 8.6.3.3** provides less restrictive rules for beams when: they are unpropped during construction; the bending resistance isn't fully utilized in design (common due serviceability considerations); and the shear connectors have a higher ductility for certain deck profiles.

Due to the importance of the load-slip characteristics for shear connectors, Ductility Category D2 and D3 connectors are only permitted for design of composite beams with partial shear connection. According to **EN 1994-1-1: 2026, 5.4.2.1(3)** Ductility Category D2 connectors can be achieved by studs welded in re-entrant decks like CompDek 54. However, due to the lack of stud embedment in many trapezoidal deck profiles, or when the more onerous Ductility Category D3 shear connectors are required the classification needs to be obtained from standard push tests according to Annex B.

SPECIFICATION – CompDek 54

Aspect	First Generation Euro Code 4	Second Generation Euro Code 4
Evaluation Method	Decking system assessed using the m-k method with historic data.	m-k method permitted only if historical data is re-evaluated and ductile behaviour is demonstrated (EN 1994-1-1: 2026, 10.7.2). Otherwise, re-testing is required.
Compliance Pathways	Reliance on legacy test data widely accepted.	Two options: a. Re-evaluate historic data for ductility b. Conduct new product testing using partial connection method according to standard tests to establish shear bond.
Supplementary Pathways	Not explicitly required for compliance.	Mandatory additional reinforcement bars in composite slabs where fire design, or poor shear bond performance is identified.
Bending Resistance	Calculate without reduction for premature crushing.	Explicit requirement to prevent premature concrete crushing before reinforcement and deck yield strength is achieved.
Design Intent	Emphasis on empirical validation via m-k method.	Emphasis on structural reliability and ductility , ensuring enhanced safety margins and robustness under normal loading and fire conditions.

SUGGEST SPECIFICATION (1/2)

Product Identification

Product Name: CompDek 54

Profile: Re-entrant rib profile with embossments designed for composite action, featuring a nominal 54mm rib height.

Cover Width: 610mm +/- 5mm

Rib Spacing: Approximately 200mm centres with re-entrant (dovetail) rib profiles.

Embossments: Embossments on the top flanges, side of ribs and at the side of pan that creates mechanical interlocking with concrete – contributing to positive composite action.

Tolerance on height of flange and web embossments 2.5mm -0.5mm/+1.0mm in compliance with **EN 1090-4: 2018**.

CompDek 54

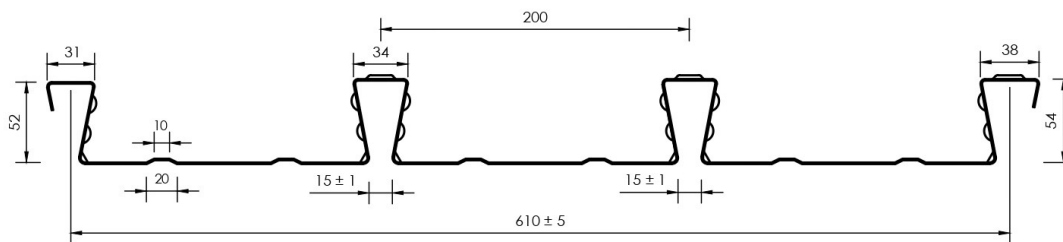

Material Specification

Base Metal Thickness (BMT): Typically, 1.00mm, 1.20mm or 1.50mm.

Steel Grade:

- G550MPa - For 1.00mm (550 MPa yield strength)
- G500MPa - For 1.20mm (500 MPa yield strength)
- G450MPa - For 1.50mm (450 MPa yield strength)

Coating Class: Hot-dipped galvanised to Z275 zinc, to **AS1397: 2021** and **EN10346-S450GD**.

Production: Production centre shall have a Factory Production Certificate in accordance to **BC1-2023**.

SUGGEST SPECIFICATION (2/2)

Design Load Tables

Design load tables in compliance with the requirements of **EN 1990, EN 1991-1-1, EN 1991-1-6, EN 1993-1-3 and EN 1994-1-1.**

Construction Load

The construction loads (Q_c) during the casting of concrete are specified in **EN 1991-1-6, 4.11.2.** The general load across the deck is 0.75kPa, with an additional of 10% of the slab weight or 0.75kPa, whichever is greater, over a 3m × 3m working area. This area should be treated as a moveable patch load that should be applied to cause maximum effect.

Supports

Minimum bearing of 50mm at ends, 100mm at intermediate supports.

Spanning Capacity

Excellent structural strength allowing for large unpropped spans typically up to 2.4m - 4m depending on BMT and slab depth, longer span (up to 9m+) are possible with temporary propping at mid-span.

Fire Testing

The galvanized steel deck shall undergo fire performance testing conducted by a specialist fire laboratory accredited by the Singapore Accreditation Council (SAC). The fire test shall in accordance with to **EN 1365-2:2014.**

The deck must demonstrate compliance with a minimum fire resistance rating of **120/120/120**, covering all three performance criteria:

- **Load Bearing Capacity (R)**
- **Integrity (E)**
- **Insulation (I)**

These requirements are in accordance with the Building Code of the Building and Construction Authority (BCA), which forms part of the National Construction Code.

Fire Resistance

Capable of achieving fire resistance level (FRL) up to 240 minutes, depending on slab design and base steel thickness without sprayed fire protection.

Biography of **Prof. Stephen Hicks**



Stephen Hicks has been Professor of Civil Engineering at the University of Warwick since 2019. He previously held senior leadership roles at the Heavy Engineering Research Association (HE RA) in New Zealand (2008–2019) and the Steel Construction Institute (SCI) in the UK (1997–2008).

An expert in composite steel–concrete structures and steel construction, he has authored numerous papers and design guides, and contributed extensively to national and international standards. Since 2022, he has chaired CEN/TC 250/SC 4, the committee responsible for Eurocode 4.

His work also includes the development of widely adopted construction products. Beyond research and development, Stephen has served on boards and governance bodies in engineering associations, product certification organisations, and environmental product declaration (EPD) programmes. He is a member of the Editorial Board of Steel & Composite Structures and Associate Editor of Proceedings of the ICE – Structures and Buildings.

Education

- **Leadership Development Program**, University of Melbourne Business School, 2017
- **PhD in Engineering**, University of Cambridge, 1998
- **BEng (Hons) Civil Engineering**, Queen Mary & Westfield College, University of London, 1993

Research Interests

- Composite steel–concrete structures
- Steel construction and shear connectors
- Buildings and bridges
- Cold-formed steel structures
- Vibration serviceability of floors
- Structural reliability
- Machine learning applications in engineering

The information provided in this brochure is for general guidance purposes only and should be utilized in consultation with a qualified Consulting Structural Engineer.

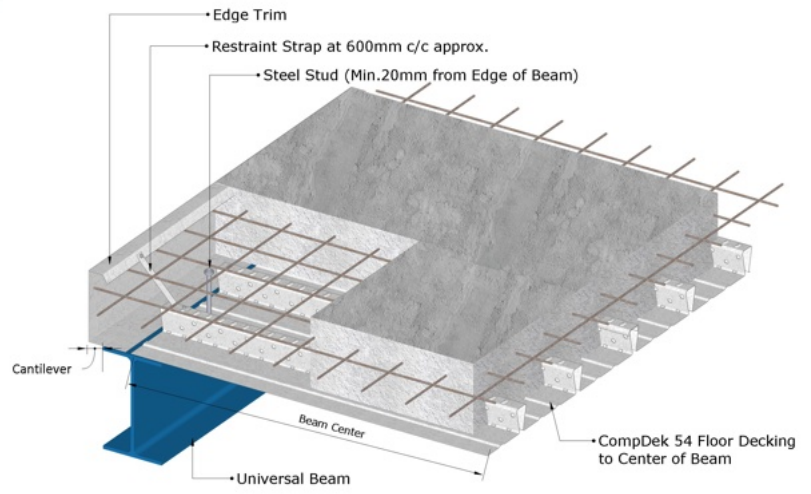

CompDek 54 - Typical End Detail (Alternative 1)

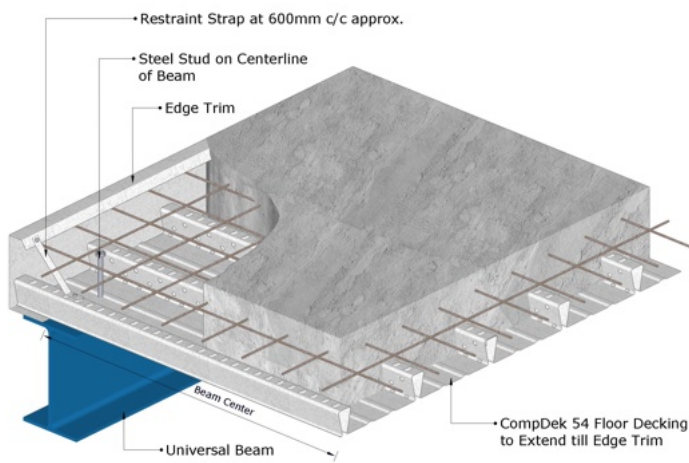

CompDek 54 - Typical End Detail (Alternative 2)

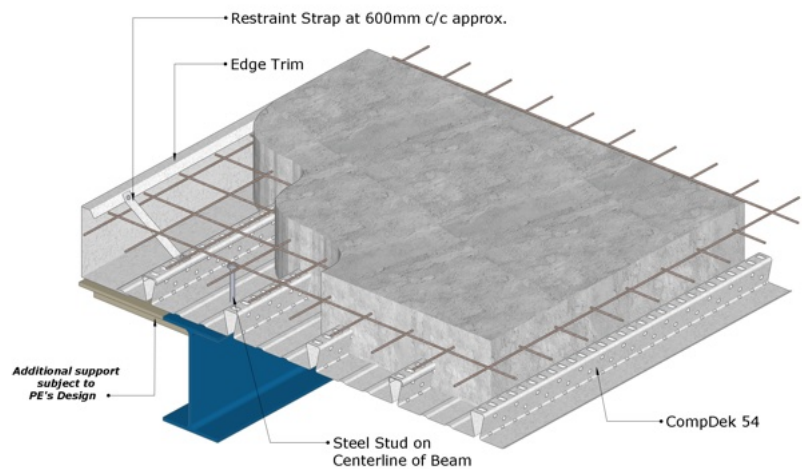

CompDek 54 - Side Cantilever with Additional Support

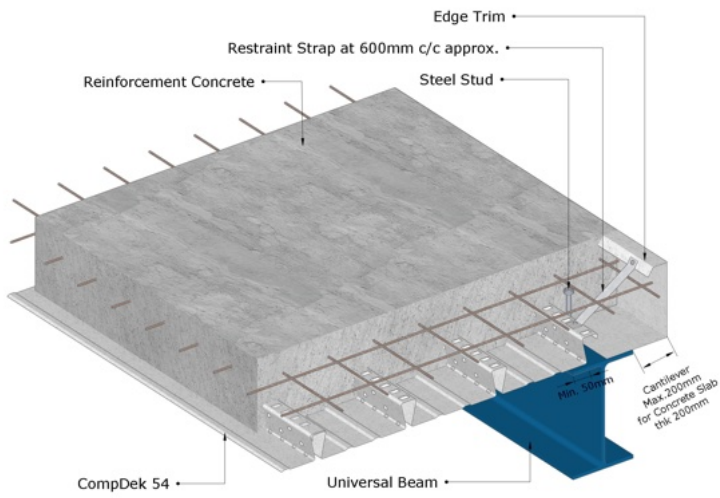

CompDek 54 - Typical Perimeter Edge Detail

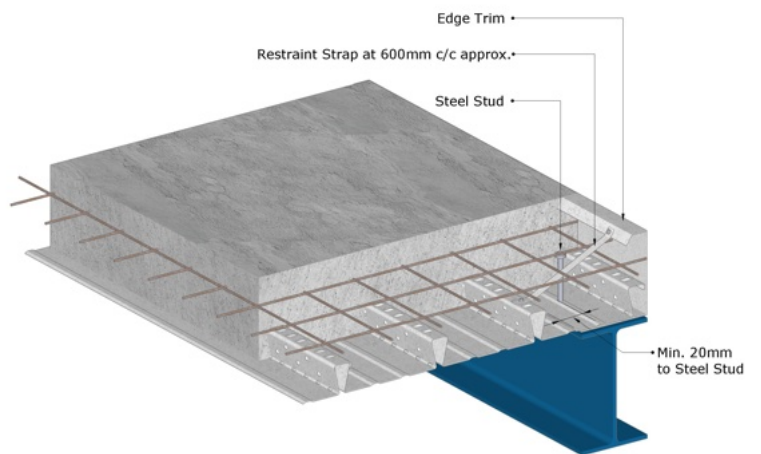

CompDek 54 - Typical Side Detail

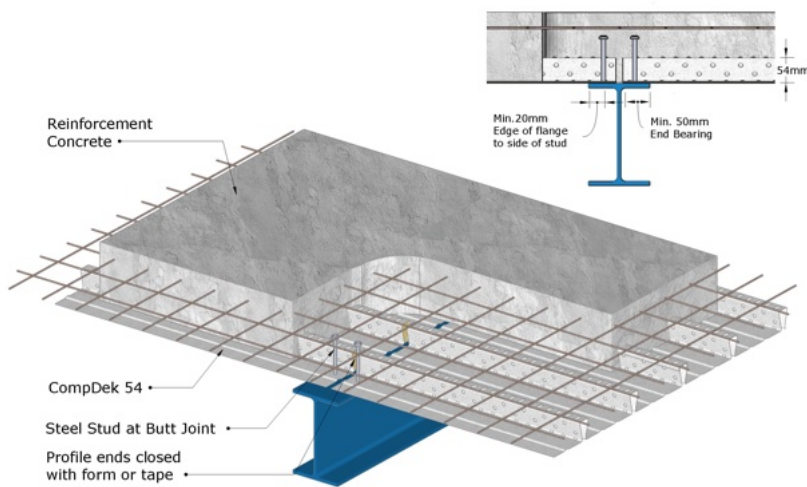

CompDek 54 - Butt Joint

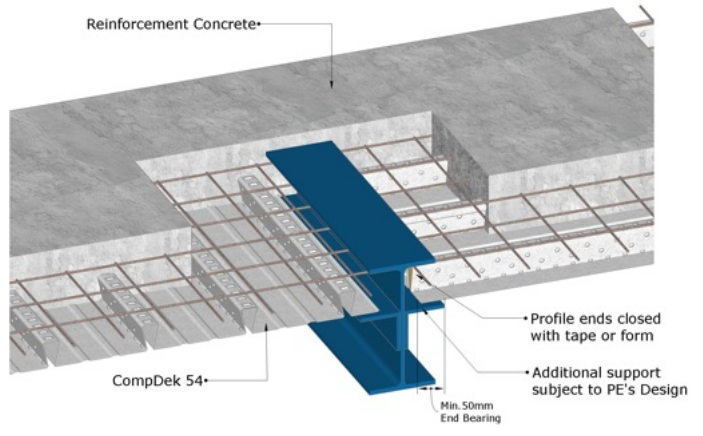

CompDek 54 - Change of Direction with Larger Angle Support

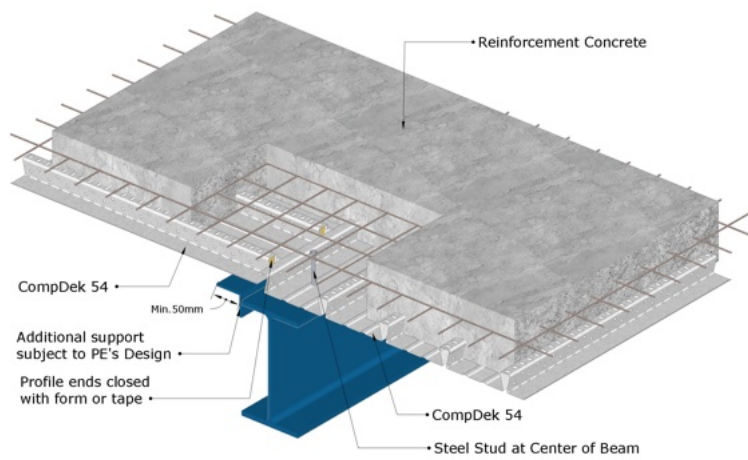

CompDek 54 - Change of Direction with Additional Support Detail

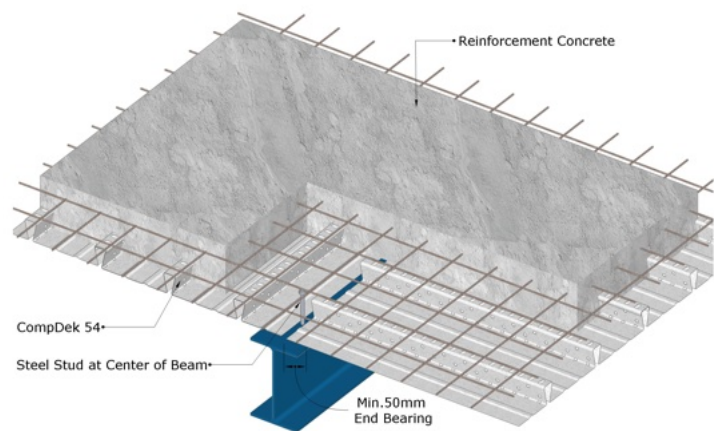

CompDek 54 - Direction Change Detail

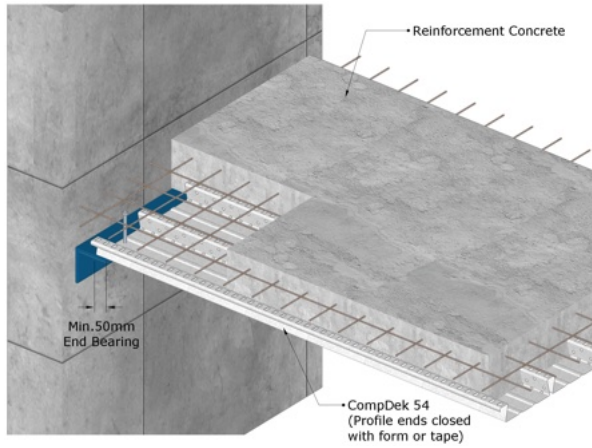

CompDek 54 - Decking Installation Inside of Wall

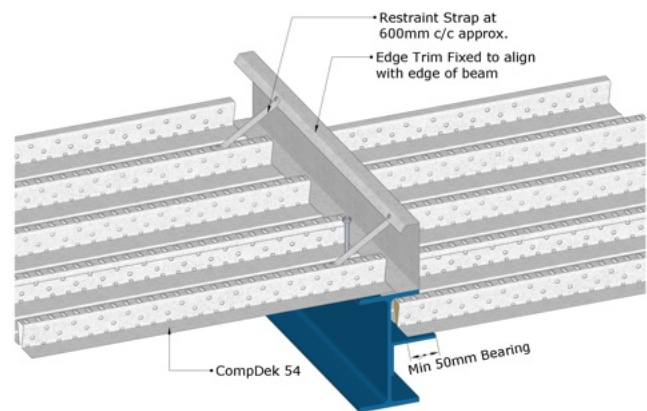

CompDek 54 - Typical Detail for Step in Floor

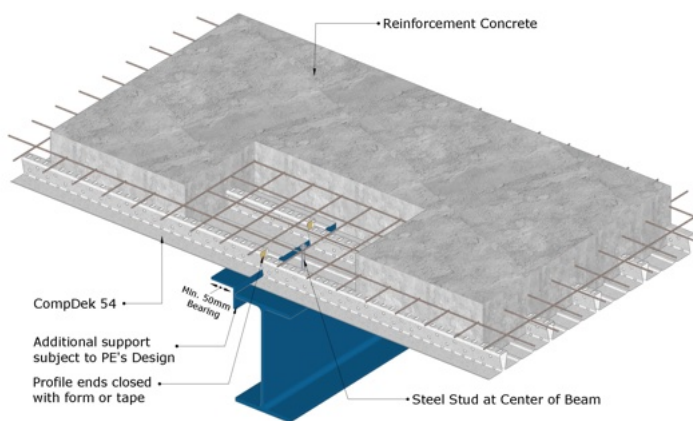

CompDek 54 - Perpendicular Direction to beam with Additional Support



**Formed from
Galvanised Steel**



**Locally Produced & Custom-cut
Using Modern Machinery**



FPC (BCI: 2023) Certified

CONTACT US

Talk to us about our competitive pricing and services. We are standing by to receive your call.

Swan Swee Construction Pte Ltd

1 Senoko Way, Singapore 758058

Tel : **+65 6755 9979**
Fax : **+65 6257 9166**
E-Mail : **sales@swanswee.com**

